

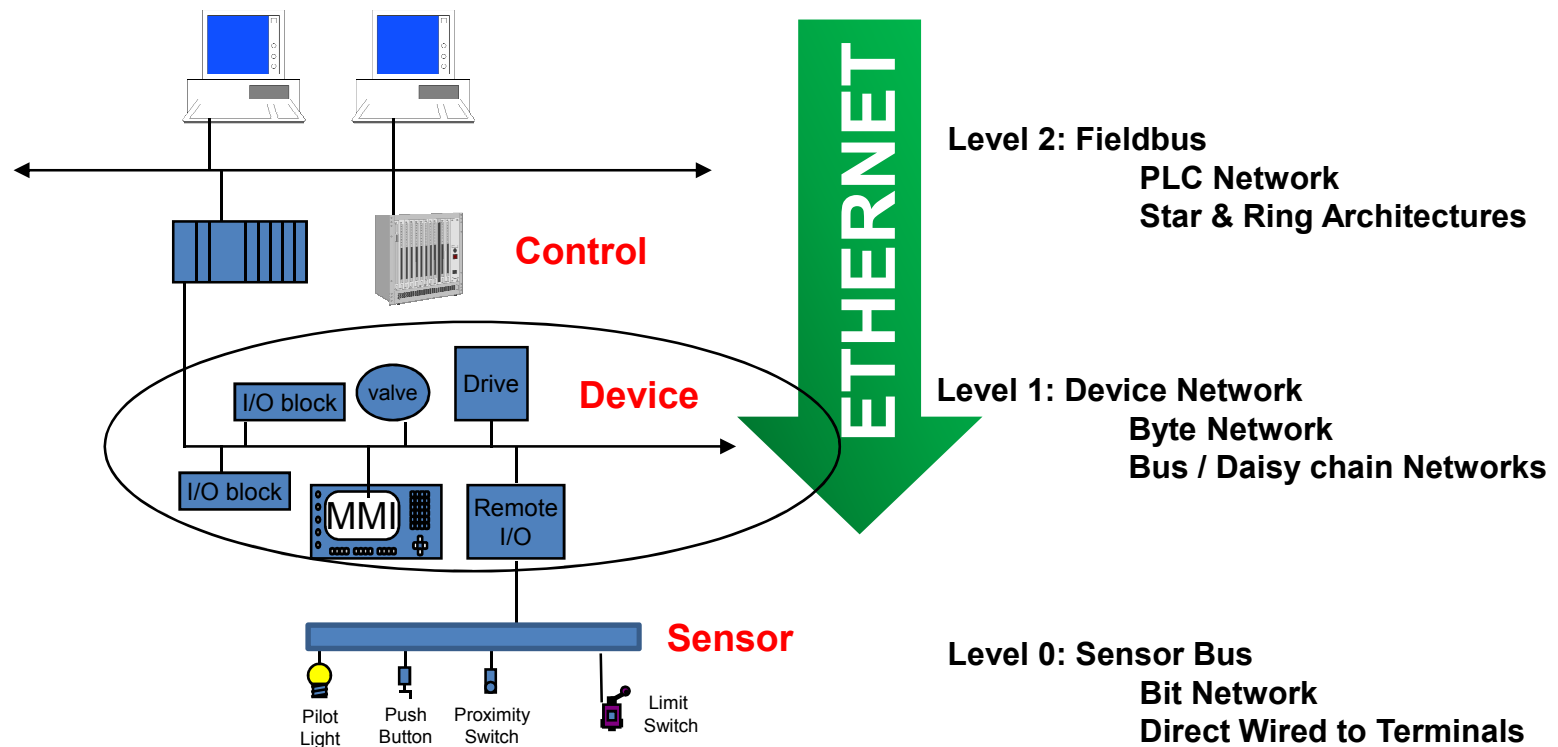

Industrial Applications of Ethernet over Power EoP

ABOUNDI technology addresses many issues facing the expansion of Ethernet downward to replace traditional Device Level communications in Industrial and Manufacturing applications. Architectures at this level coupled with Environmental factors need to be addressed.



Ethernet used for PLC applications is different

Ethernet Challenges

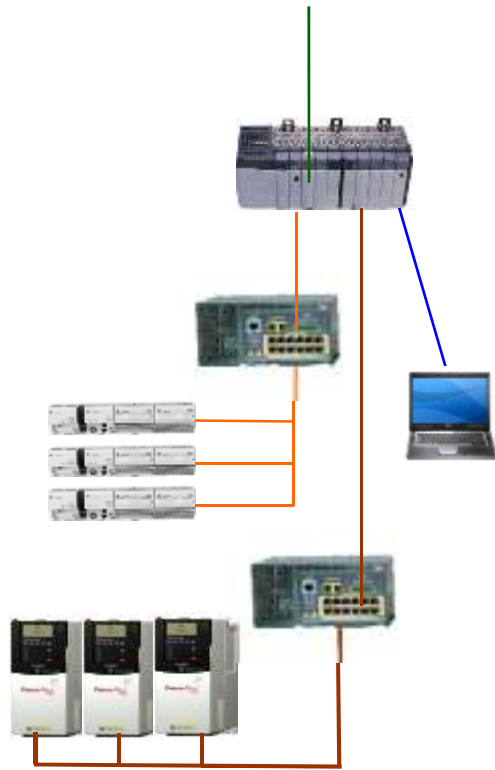

- PLC may have several isolated Ethernet networks to limit or avoid collisions or segment application.
- Wiring at the I/O level is more suited for a Bus or Daisy chain architectures.
- Connected devices at the I/O level are typically limited to between 8 and 30.
- Devices are usually exposed to harsh environments and require rugged terminations

Ethernet in Automation I/O applications

Issues with Wired Ethernet I/O networks

1. **Topology.** Creating a Bus from a traditional Star tree configuration
2. **Connectors.** RJ-45 not suitable for vibration and harsh environment
3. **Cable lengths.** Limited to 100 meters for copper connections
4. **Susceptibility to Noise.** Requiring special shielding of cables
5. **Integrity.** Ethernet cables can be bent, crushed or cut
6. **Cost.** Ethernet connections are more expensive than traditional I/O networks

Issues with Ethernet I/O over Wireless networks

1. **Speed.** True Wireless TCP/IP speeds are slower than wired connections
2. **Interference & Reflections.** Performance of device requires proper placement
3. **Security.** Requires increased security to prevent unauthorized access
4. **Susceptibility to Noise.** Other Radio devices can interfere with communications

Topology a major issue in wiring and installation costs

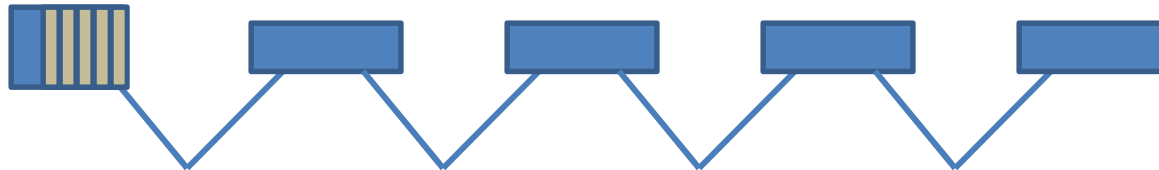

(Remote I/O, Profibus, Modbus+, ControlNet, DeviceNet)

Traditional wiring prior to Ethernet was optimized to work off a bus or daisy chain wiring

Creating a Bus from a traditional Star tree configuration is a major issue when applying Ethernet in traditional I/O applications with distributed devices.

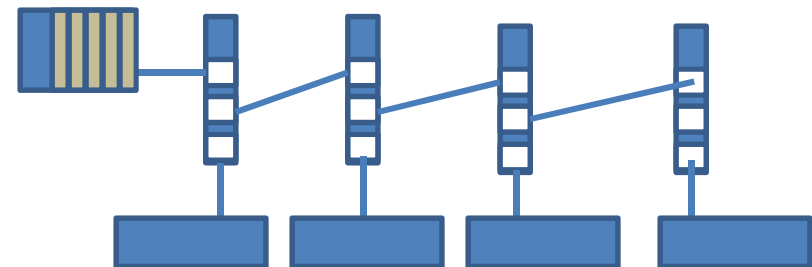
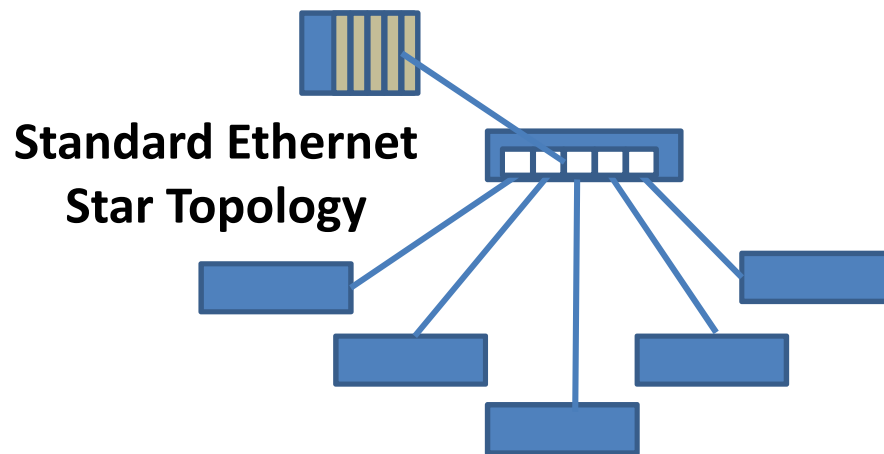

Ethernet switches creating a Bus Topology

ABOUNDI Products:

1. Layer the High Frequency Ethernet communication over the common power wires (AC or DC voltages) and thus eliminates a need for a separate communication wire in I/O networks.
2. Operates at a 200 Mbps which is two to four times faster than Wireless without issues of security and dead zones.
3. Can extend wired communications to 300 meters (1,000 ft.) without requiring expensive Fiber-optic cabling
4. Can create Isolated channels and allow VLAN type communications over a common wire
5. Can bridge isolated networks using power or outdated coax cabling that may exist from previous communication technologies

Ethernet Wiring at the I/O level

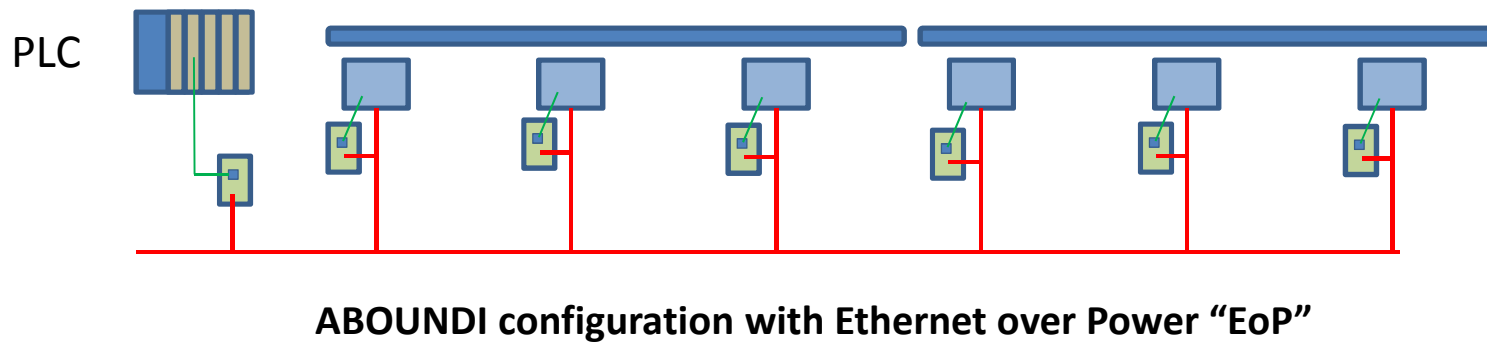
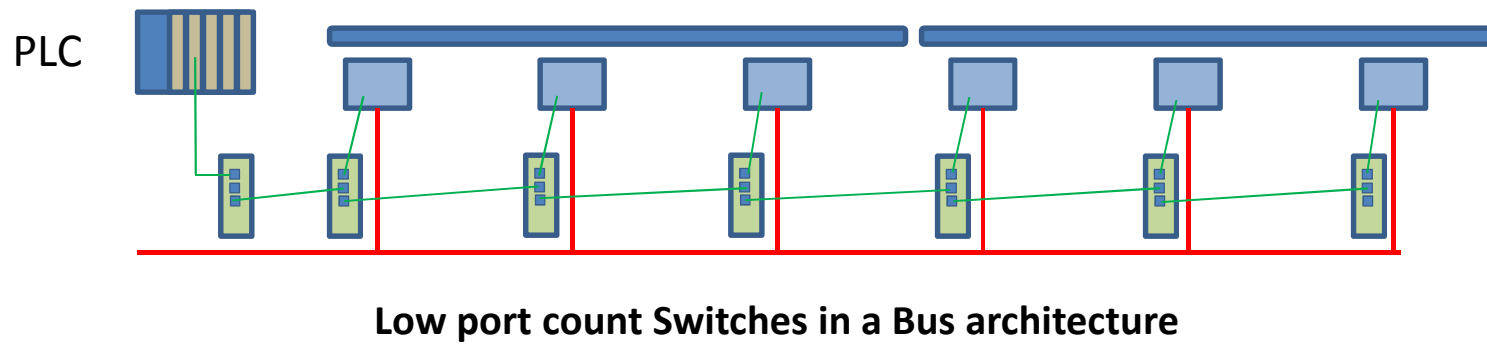
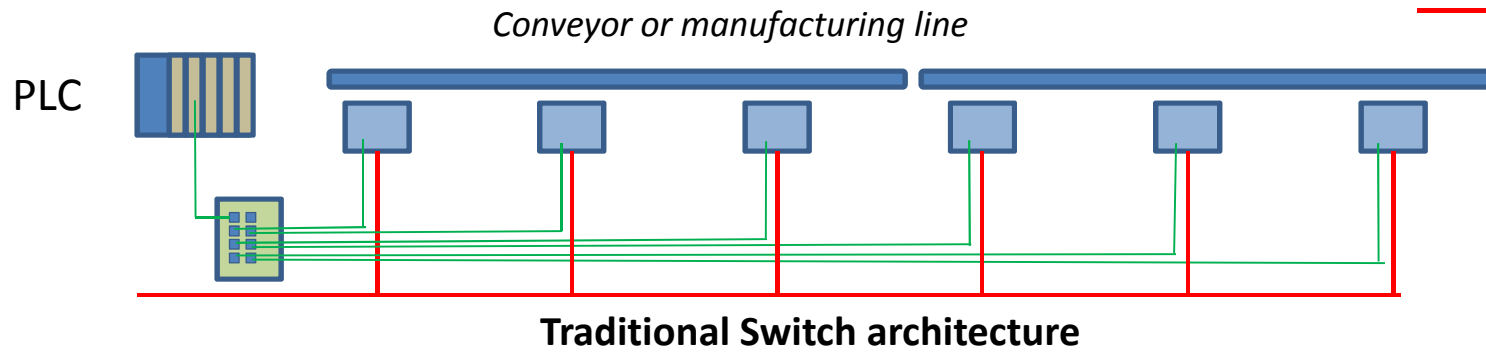
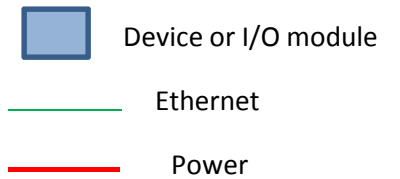

Details of Technology using 24 VDC wiring at the I/O level

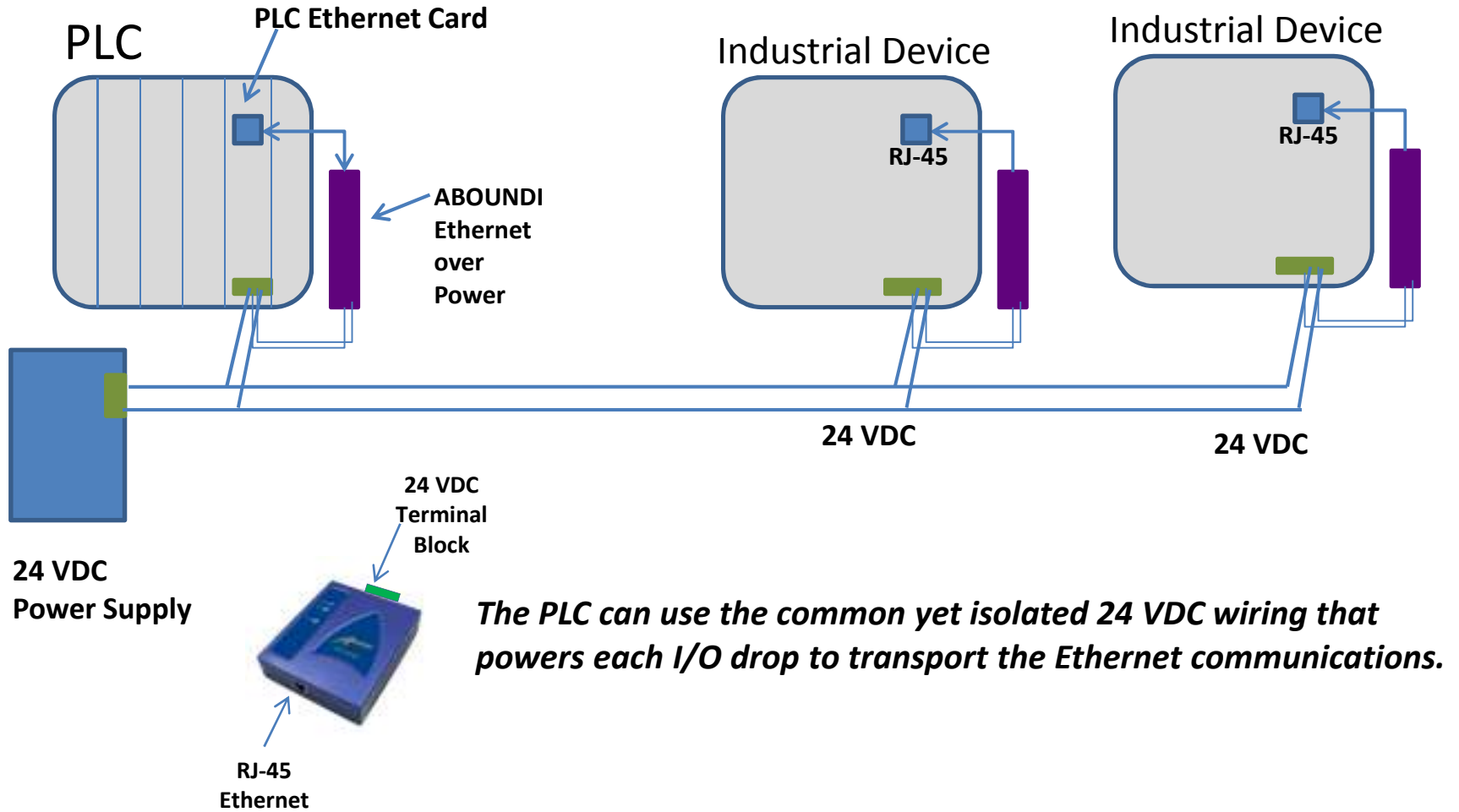

Installation and maintenance of Ethernet cables on the plant floor can be expensive



The cable can be the cause of many disruptions in Ethernet communications. Identifying and repairing a damaged cable is very costly.

Routing new communication cables for newly added devices can also be very expensive.

ABOUNDI solutions provide a cost effective alternative by using the power connection common for every device.

ABOUNDI Technology eliminates the need for a separate wire to carry the Ethernet Communication

Power Line either 120VAC or 24 VDC to each I/O device

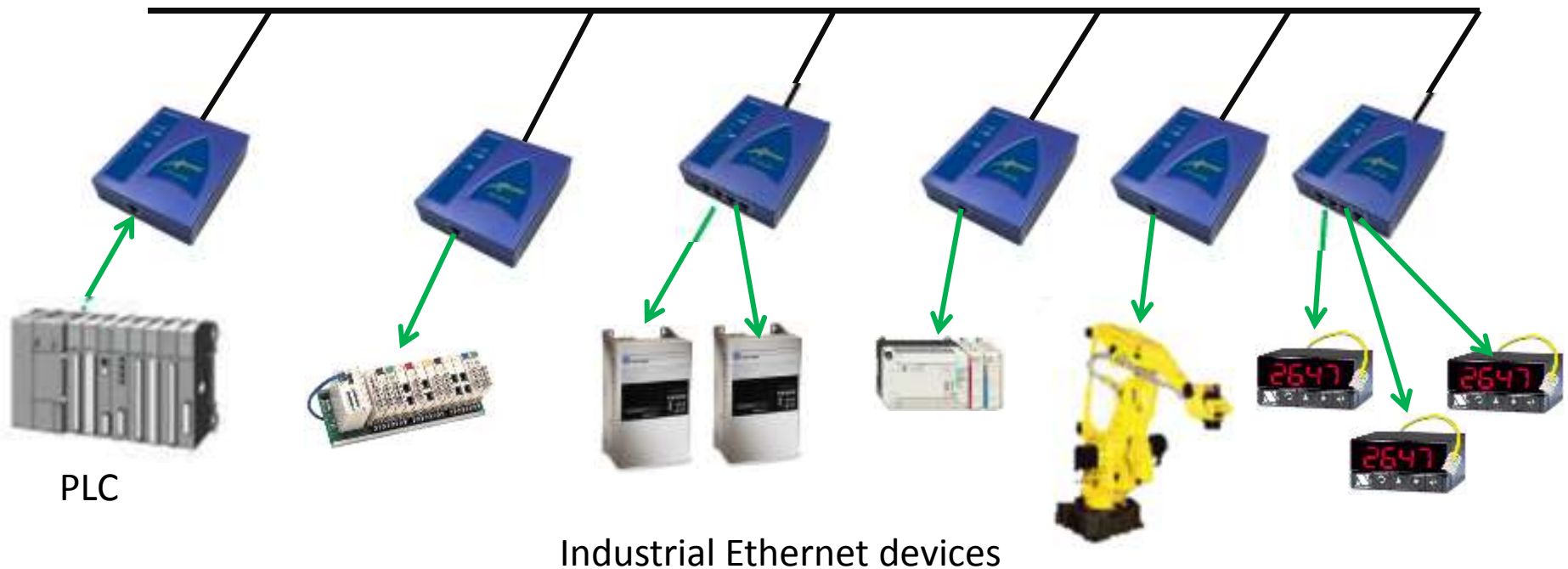

Layering the Ethernet communication over the power that is required on each I/O device eliminates the need for switches and thus simplifies wiring and reduces cost.

ABOUNDI Technology can bridge Isolated or remote networks

Power Feeds, Telephone or unused Coax Cable

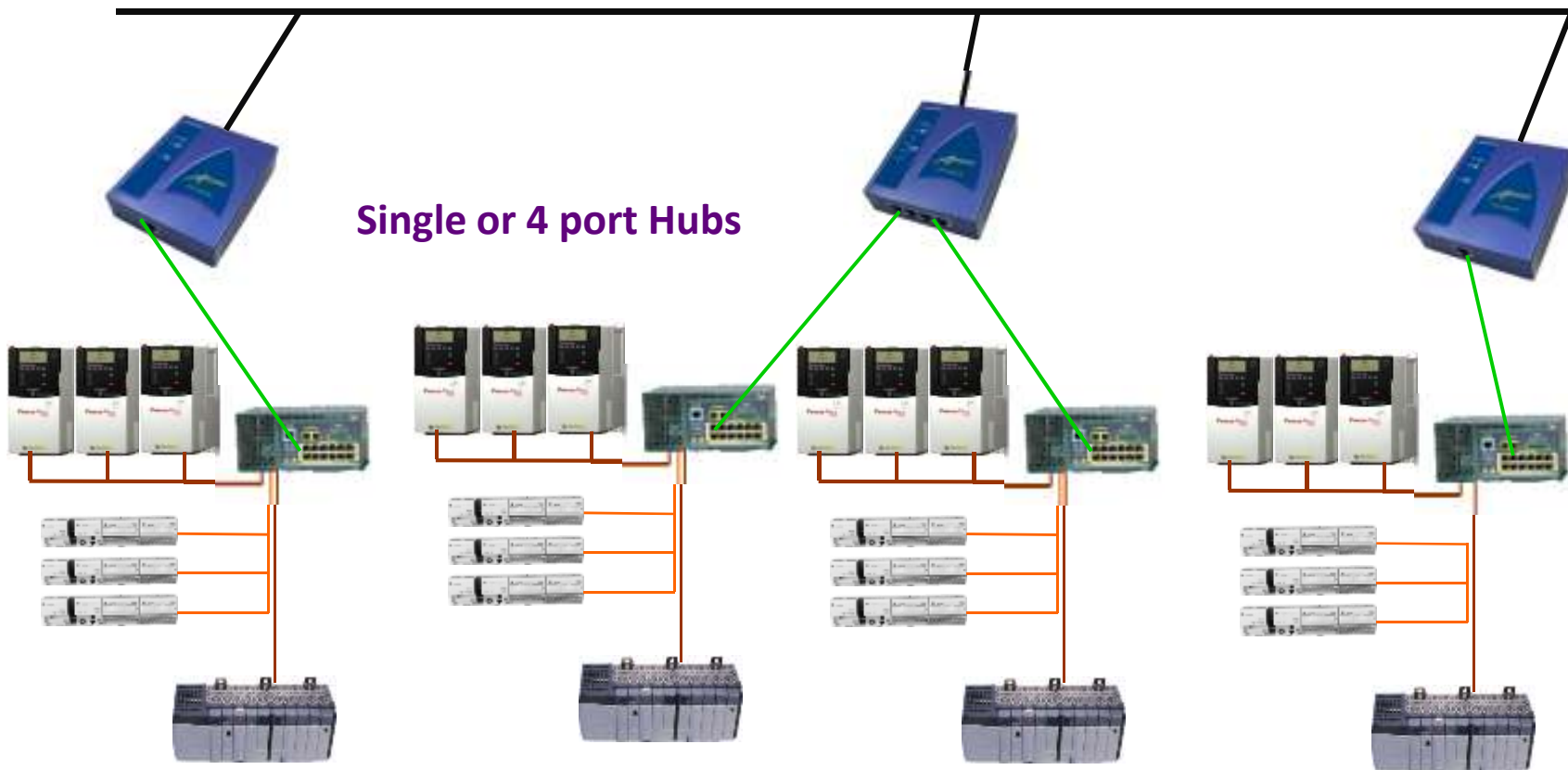

By Embedding the ABOUNDI Technology in each I/O Product you eliminate Ethernet Wiring & Connectors at the I/O level

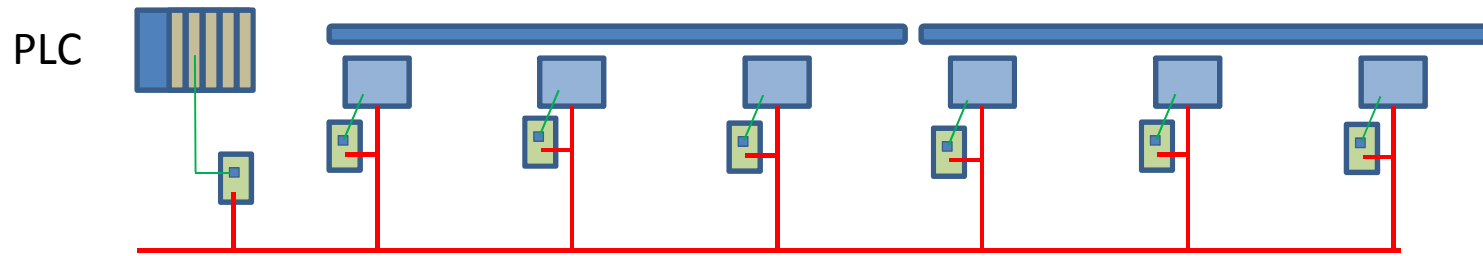

External ABOUNDI configuration

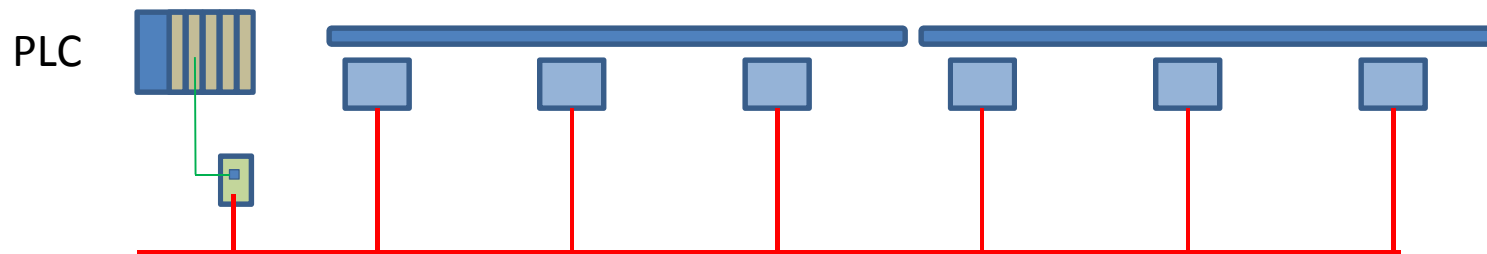

Embedded ABOUNDI configuration

Connectors

RJ-45 connectors for Ethernet communications may not be suitable for many industrial applications in which vibration and the harsh environment can create problems for the physical connection.



Move to Industrial Ethernet Connectors can be expensive!



One solution is using very expensive connectors that creates a tighter and more secure connection.

ABOUNDI addresses this problem by eliminating the need for a separate Ethernet cable. The only connection to the Field device is power if the ABOUNDI technology is embedded into the device. The only connection required will be the power to each industrial device.

ABOUNDI Embedded EoP OEM design

Device vendors can license or purchase ABOUNDI Boards to interface directly and reduce the cost and complexity of Ethernet connections.

Eliminates the need for any Ethernet Connector!

100 to 240 VAC or 12 to 48 VDC

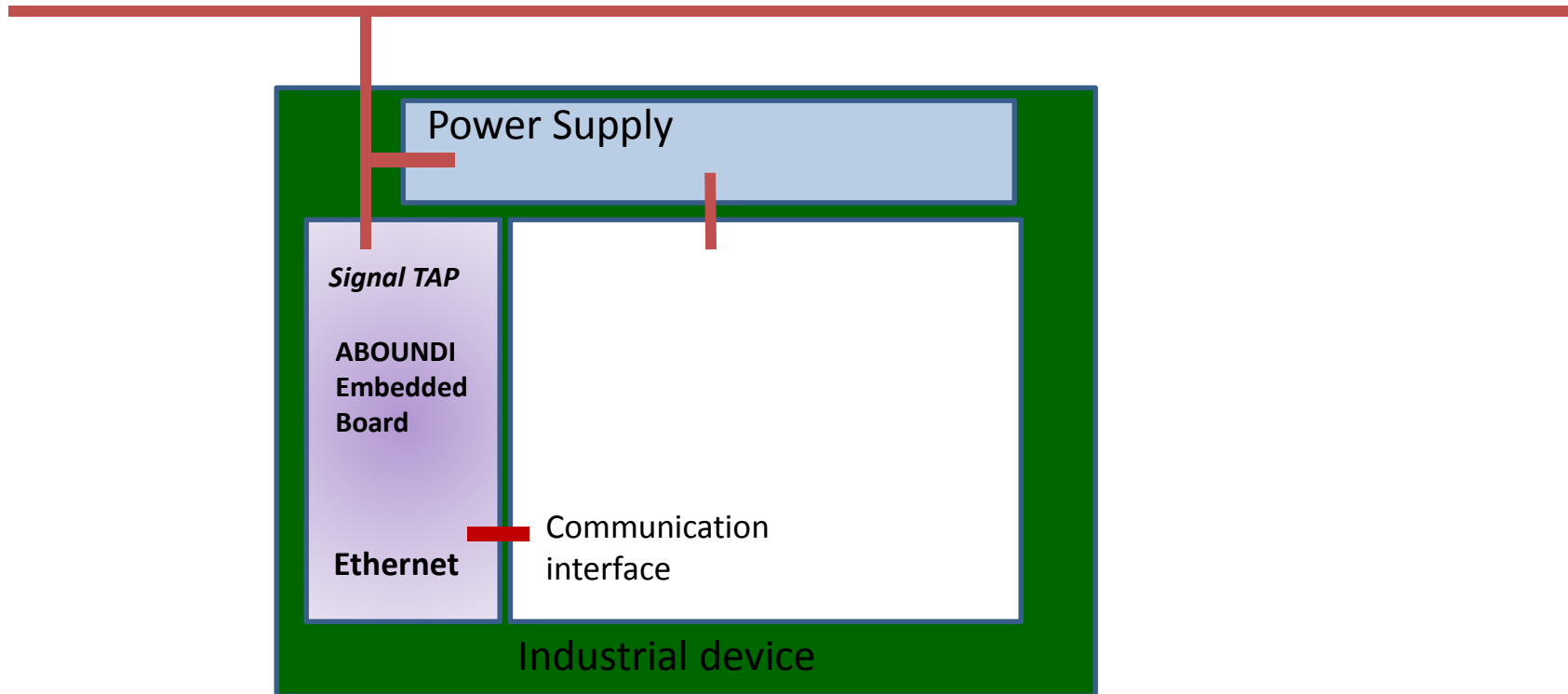

About the Technology

Now Aboundi Inc. has released a new implementation of power-line Ethernet called Electric Connect, which operates over any 100 to 240 VAC 50 or 60 Hz power line. Electric Connect does not have the poor performance of earlier versions. Aboundi, has produced a set of products that are optimized for plant-floor networking and enterprise use.

The product operates at 85 Mbps, which is faster than the current 802.11g (54 Mbps), with a throughput of approximately 35 Mbps. The key to the new implementation is orthogonal frequency division multiplexing (OFDM). OFDM, also sometimes called discrete multi-tone modulation (DMT), is a technique for transmission based upon the idea of frequency-division multiplexing (FDM), where each frequency channel carries a separate stream of data. A single transmitter sends data using many (dozens to thousands) frequency sub-bands simultaneously. The frequencies and timing are chosen in such a way that the data are orthogonal—i.e., they may be received independently without mutual interference. Due to the mathematical structure, each sub-band overlaps its neighbors in a signal with high resistance to noise and interference. This provides better noise filtering, which will allow higher spectrum efficiency and, in turn, more resilience to interferences, resulting in better time-frequency synchronization and, therefore, maintaining a higher data rate.

The APL1000 Ethernet Bridge is plug-and-play, supports up to 16 drops (each drop can support up to 4 Ethernet connections) on a single network domain and is supplied with 56-bit DES encryption for data transmission security and network segmentation through network password configuration. The bridge may be used with any router or switch, but Aboundi also provides a network router for the system. The Aboundi router and bridges support VPN pass-through and multiple security modalities.

ABOUNDI leverages its Patented Technology to improve communications for Industrial Applications

Patent 7660345 A transceiver device for coupling between a power line and a network interface unit includes a power line modem for transmitting and receiving data between the power line and the network interface unit and a power circuit coupled to the power line modem that is adapted to deliver a DC power signal to the network interface unit. The power circuit includes a discovery circuit adapted to determine the type of network interface unit that is attached. A load path control circuit switches the DC power signal between a PHY interface and a connector interface of the power line modem based on the determined type.

Patent 7592717 A power mains data transfer system according to one embodiment of the present invention comprises a data transceiver, a first data path to the power mains over which a data path is maintained, and a second, power path connected to the UPS output and provides a connection from which data transceiver operating power is derived. Various further embodiments provide multiple data equipment data input/output and/or power connections, and optional internal switching and filtering features. Thus, according to the present invention, an apparatus is provided for reliable data transfer over power mains even when there is an interruption in the mains' data integrity, e.g. via a UPS device, there along.